

**HOME
SWEET
HOME**



Everyone needs a home...
even the homeless.



Hence **HOME SWEET HOME**,
a design + communication initiative with two goals:

- provide some homeless people with DIY cardboard "houses" made from cardboard boxes which can be found in any dumpster
- use these temporary shelters as billboards to publicize a simple truth: **NO ONE** should live in a cardboard box.
- concrete suggestions of what we can all do to help.

THE APPROACH

DO

Good Samaritan

Mother
Theresa

FEW

ALL

Local
associations

Greenpeace

TELL

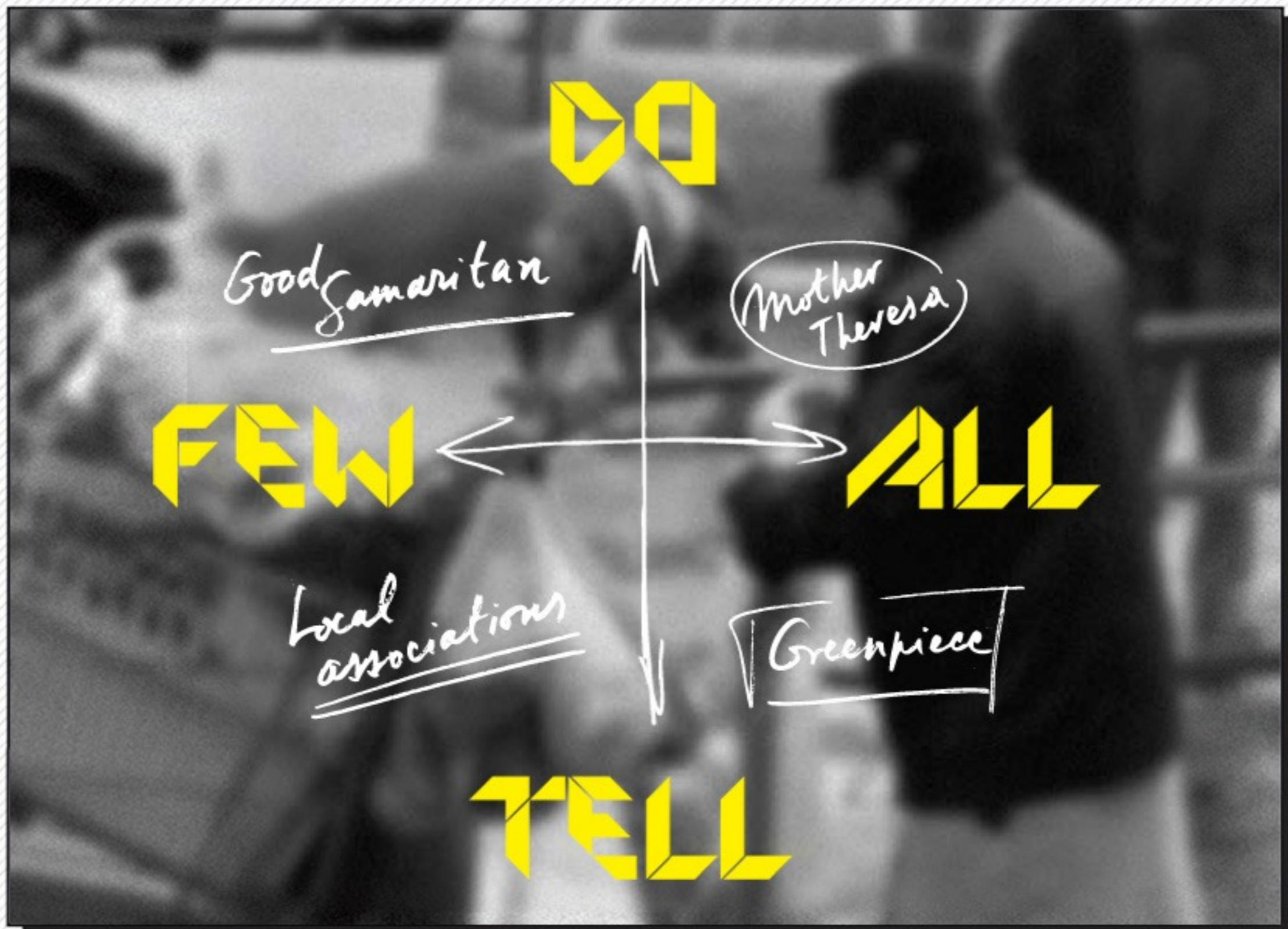

HOME
SWEET
HOME

Mother
Theresa

DO-ALL

Some people want to save the whole world.

HOME
SWEET
HOME

Good Samaritan DO-FEW

Some people want to help a few people they know.

HOME
SWEET
HOME

Greenpeace **TELL-ALL**

Some people want to raise everyone's awareness.



Local associations TELL-FEW

Some people want to raise awareness of those close to them.

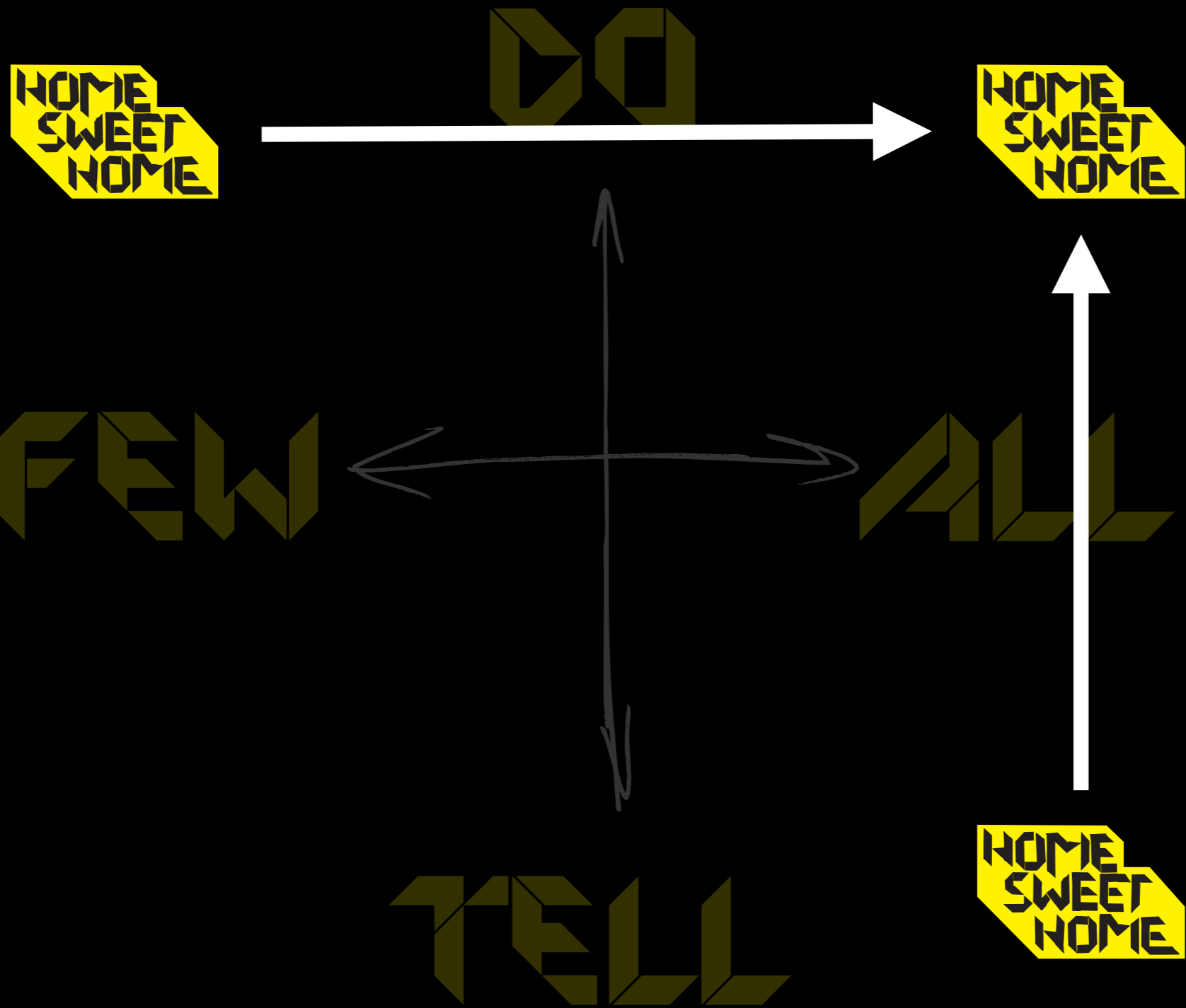

CONTENTS



A - portraits

(video interviews, photos, texts)

sensibilisation

B - installations

(cardboard constructions, videos)

C - other materials

(manuels, cardboard objects...)

call to action

PORTRAITS



- **video interviews** of ex-homeless or currently homeless men and women telling us their life stories.
- **direct relationship with the homeless**, to make us face their lives and problems, to provide an honest look and make us see them for who they truly are: ordinary people with "extraordinary" problems.

PORTRAITS



Anastasya (6min 30s)



PORTRAITS



- photo gallery
- around 20 photographers from all over the world

Salvo Galano
Slim Letaief
Zorana Jevtic
Leslie Shoots
Patric Modé
Carli Bauza
Andriy Mishchenko
Ognjen Topalovic
Sonja Mijajlovic
Stelios Tsagris
Fatima Guidice Bravo

Acim Vasic
Alejandro Sanchez
Ivona Sijakovic
Manon Boutié
Filip Roca
Tamara Boskovic Dereta
Maud Benardeau
Marijo Faure
Duska Stefanovic
Katarina Popovic
Tatjana Radic



Salvo Galano

From the book "Sidewalk Stories"
Ronald Rosario B., New York City 1999
© Photo Salvo Galano



Salvo Galano



Slim Letaif





INSTALLATIONS



- different "models" of cardboard shelters
- installed in the top tourist spots
- *Characteristics of all cardboard house models:*
 - made minimalistically from cardboard boxes:
no sticking, cutting only
 - easy to make: all that is needed is cardboard boxes (number of boxes depends on the "house model") and a knife or scissors.
 - easy to reassemble and move from place to place
 - isolated from the ground and very stable

CONSTRUCTION

HOME
SWEET
HOME

MODEL
BASIC 5 × 

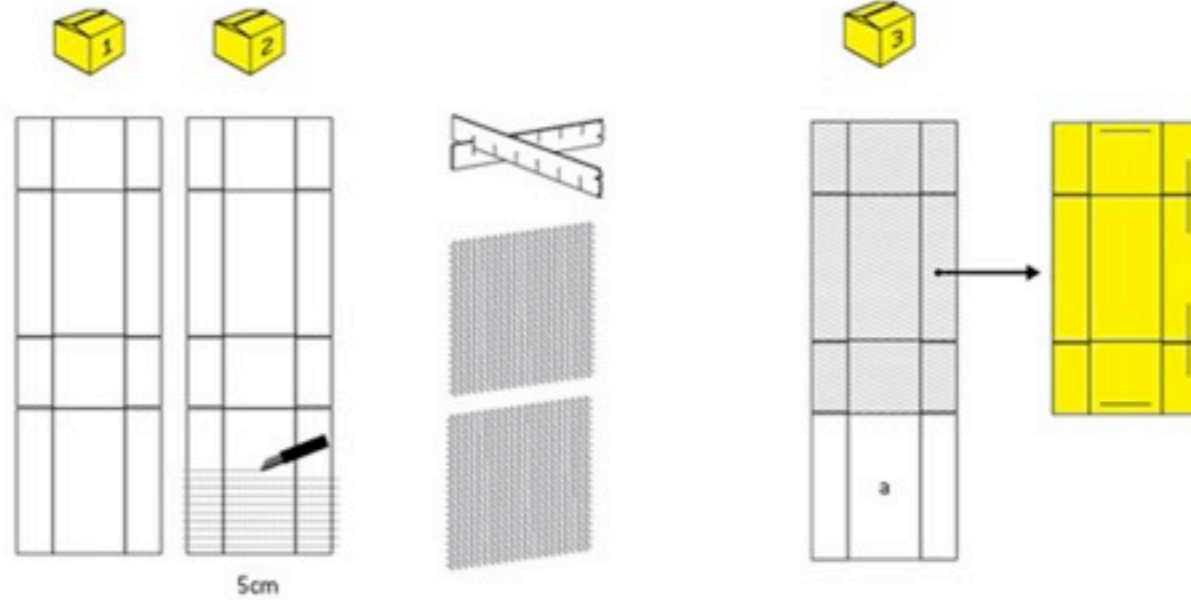

CONSTRUCTION

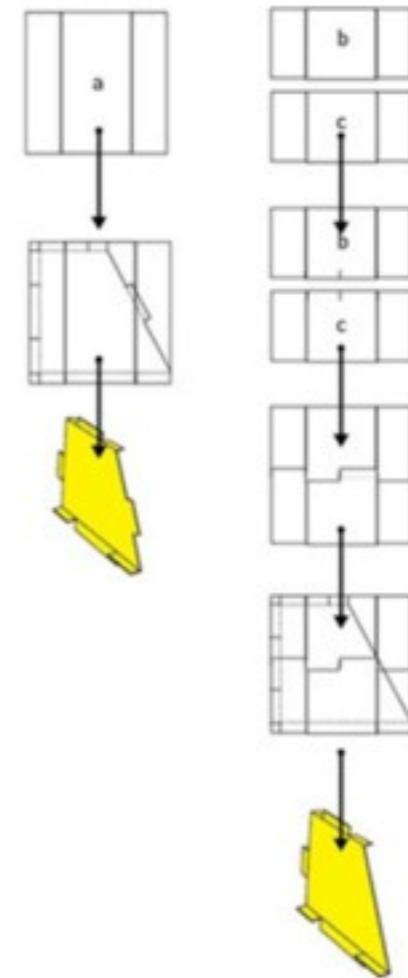
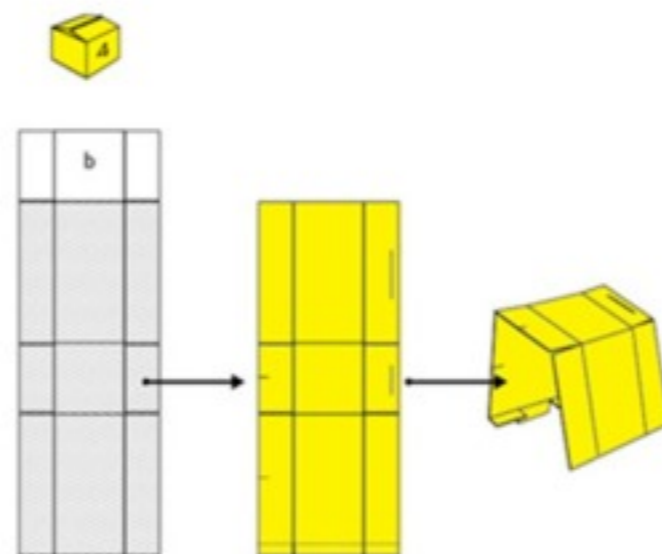
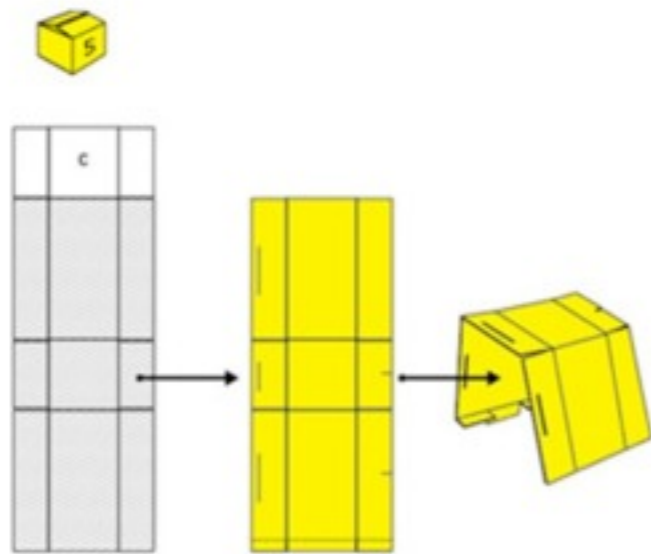

CONSTRUCTION

HOME
SWEET
HOME

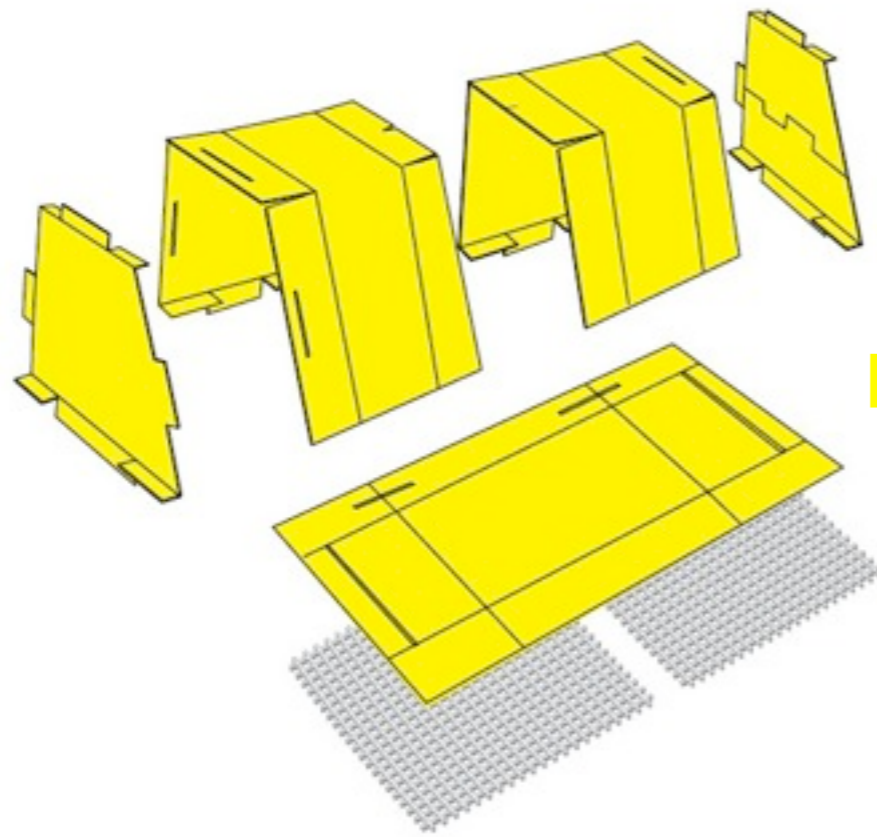

INSTALLATIONS



The houses are presented

- in **installations** (always with the headline, e.g. *Nice studio with beautiful view* will be the headline for the basic model of card-board house installed at the Trocadero looking to the Eiffel Tower; *Nice 2-room flat with private garden* for a two-part cardboard house in the Bois de Boulogne...)
- in **videos** showing how they were installed, how they were moved around, how people reacted to them
- in **print ads** looking like real estate ads

INSTALLATIONS



Studio with beautiful view



INSTALLATIONS



Studio in city business center



INSTALLATIONS



Studio in heart of town



Nice studio with beautiful view
Partick Modé

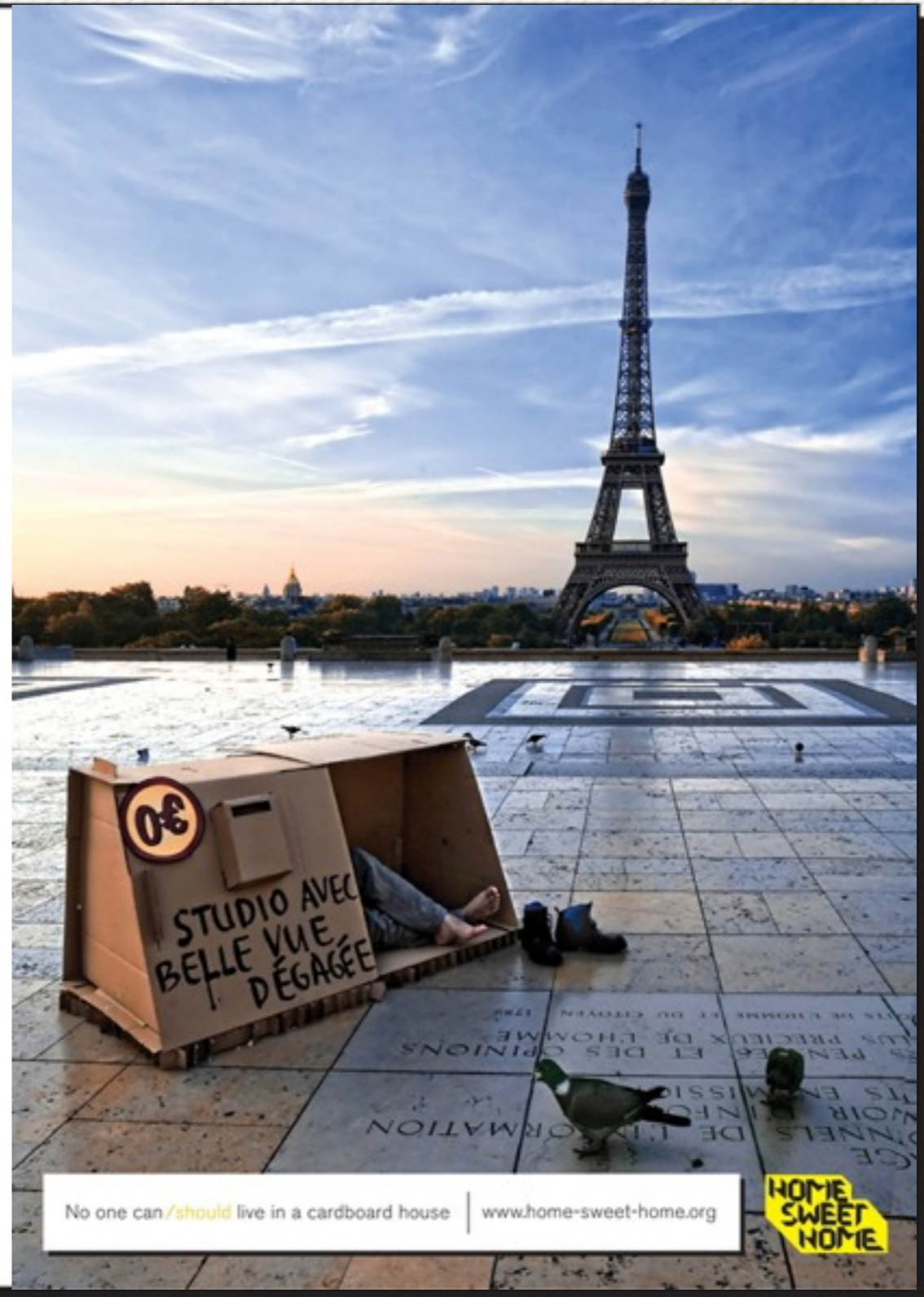

OTHER MATERIALS



- **manual** presenting all the models and how to make them
- **postcards** featuring a photo of one of the house models and a compelling message
- **postcards** featuring portrait photos
- **cardboard objects**
which can be sold on the exhibition opening to raise money for local problem solving



ONE EVENT

(Belgrade, 19-23/4/2010)













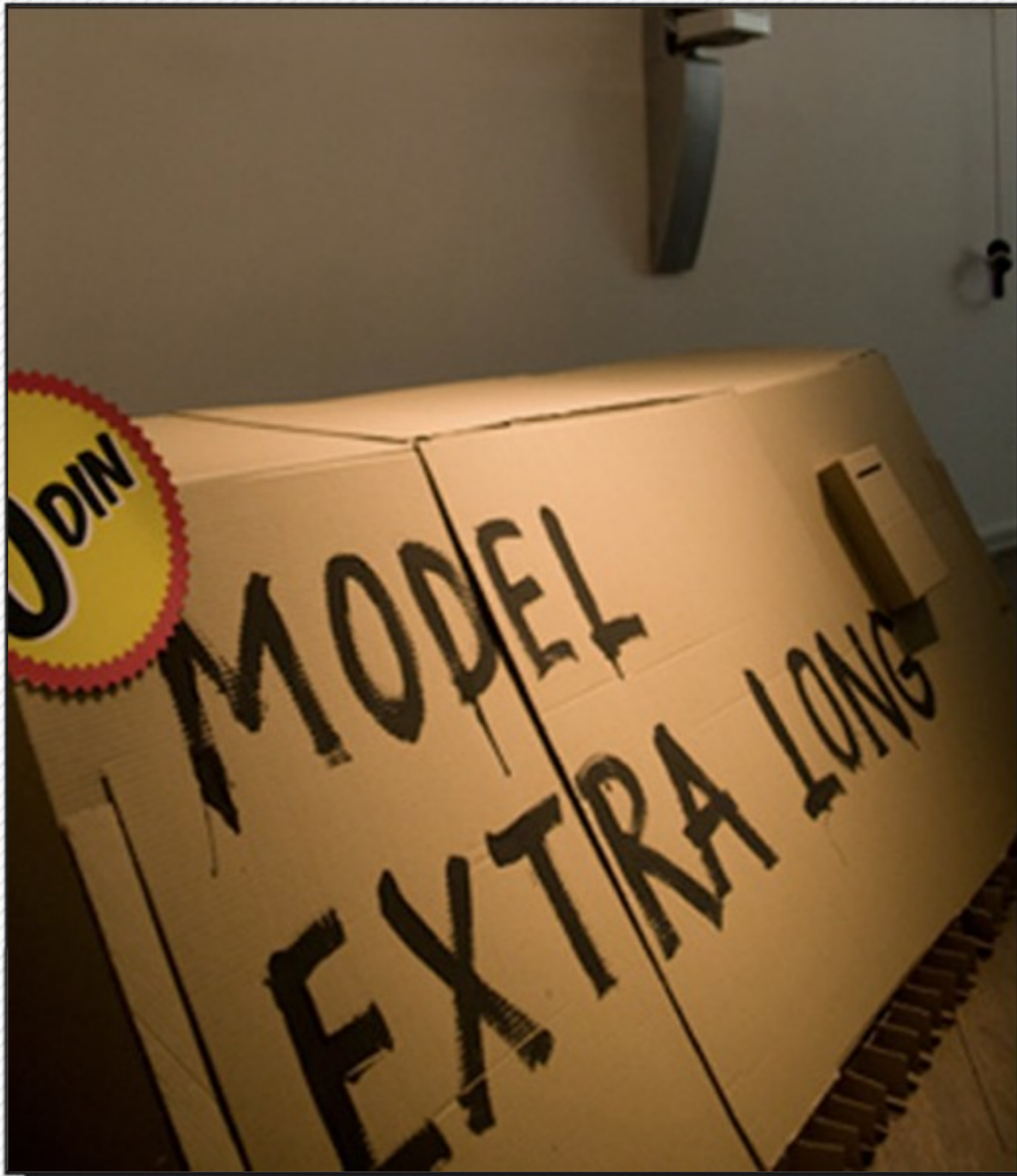







Everyone needs a home...
even the homeless.



www.home-sweet-home.org